

# **Installation and Operating Manual**

**(Doc no: ITQ-IMM-04-A)**

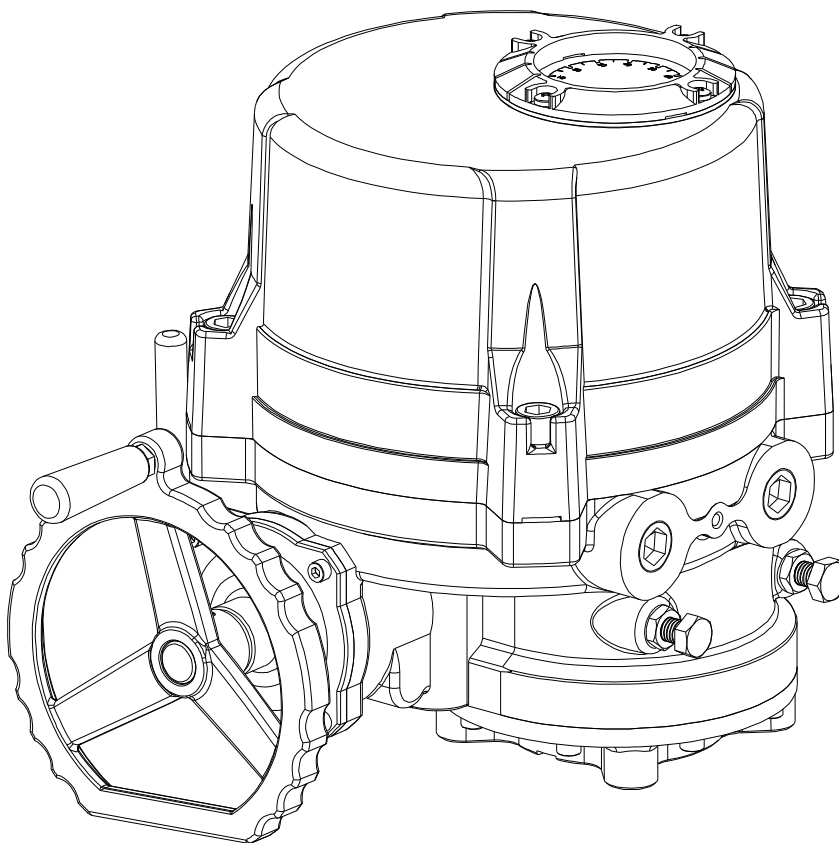

**(ITQ-0100, 0160, 0240, 0350, 0500, 0800  
1100, 2000, 3000, 6000, 9000)**

74-6, Chun Ui-Dong, Won Mi-Gu, Bucheon City, Kyoung Ki-Do, Korea

Tel : 82-2-855-1365, 66 Fax : 82-2-855-1367 E-mail : [roy75@i-tork.com](mailto:roy75@i-tork.com)

## Table of Contents

1. Before operating actuator	.....	3
2. About ITQ actuators	.....	4
1) External component	2) Internal component	5,6
3) Specification	4) Features & Structure	7,8
5) Mounting Base (ISO5211)	6) Removable drive bushing	9
3. Sizing and Application	.....	12
4. Setting	.....	13
1) Manual operation	2) Limit switches	
3) Torque switches	4) Stopper bolts	14
5) Indicator		
5. Location of actuator on the pipeline	.....	15
1) Location of actuator on the pipeline		
2) Orientation of actuator		
6. Electrical wiring	.....	16
1) Before wiring	2) Electrical wiring	
3) Checking the rotating direction of actuator	4) Commissioning(Electrical)	
7. Others	.....	17
1) Jamming		
2) Special tools for setting		
8. Caution	.....	17
9. Trouble Shooting	.....	18
10. Maintenance	.....	18
1) Lubrication	3) Maintenance	
2) Regular operation	4) Others	

## Many thanks for purchasing our ITQ series electric actuator!

For safe and proper operation, please carefully read this manual before using it and save it for reference.

Important Note : The contents of this manual are subject to change without individual notice .

### 1. Before using actuator

Please check individual test report, nameplate and electrical wiring (inside of actuator).

- 1) Visual Check : Painting, Indicator, Hand-Wheel etc
- 2) Specification: users may check test report and name plate to be sure actuator is suitable for requirement specification of application
- 3) Optional Items : Check if all optional items are correct.
- 4) Check if electrical specification is correct (wiring diagram inside of the actuator, name plate).
- 5) Check if the electrical power is correct.
- 6) Check if instruction manual, test report (Warranty paper) and electrical wiring diagram are supplied.

If there is any discrepancy, please ask local distributor of I-Tork controls Ltd to solve or replace any discrepancy immediately.

## 2. About ITQ actuator

### 1) External components

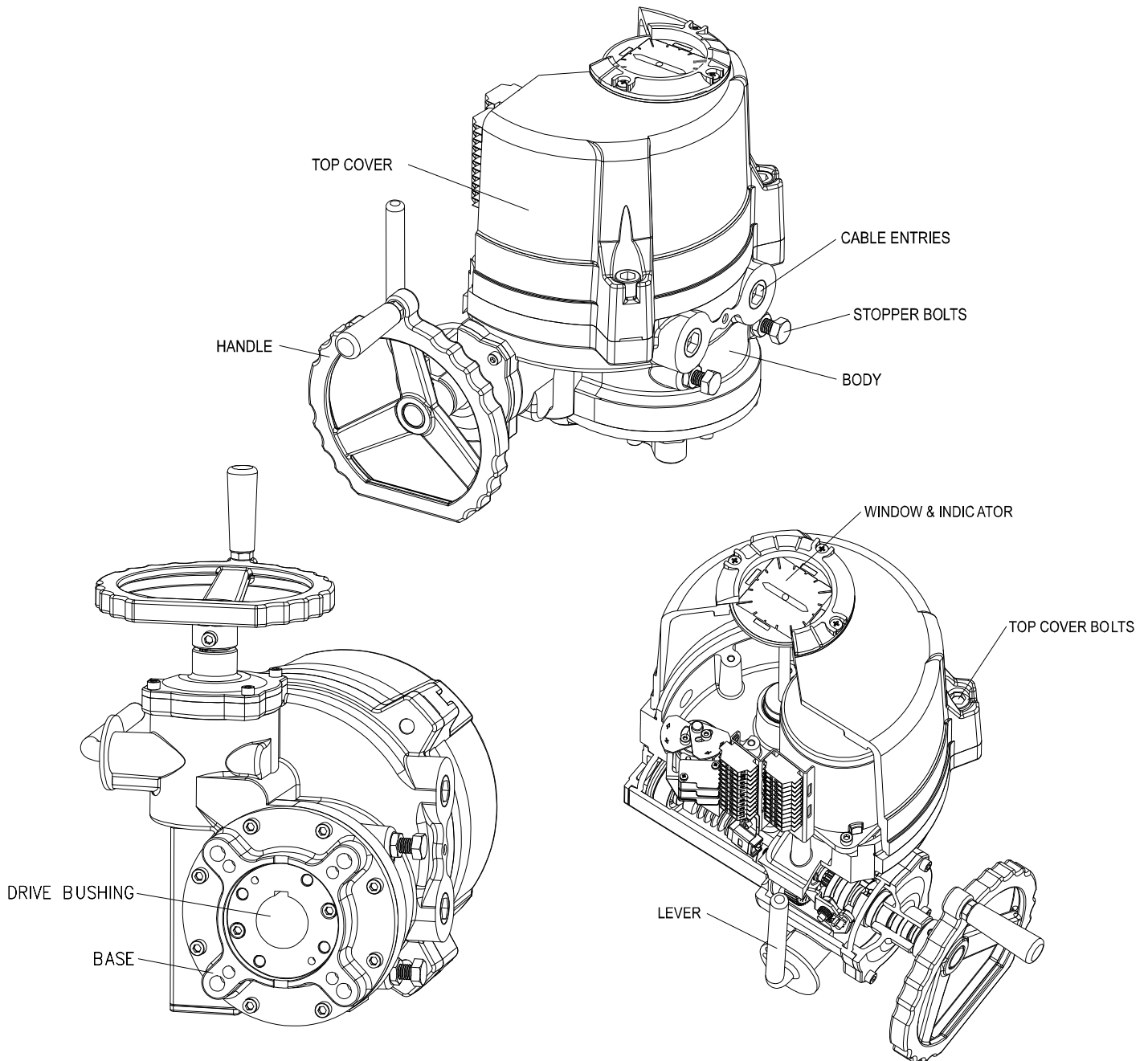

ITQ0100 ~ ITQ3000

**ITQ ELECTRIC QUARTER TURN ACTUATOR**  
**Installation and operating manual (ITQ-IMM-04-A)**

**i-tork**  
CONTROLS Ltd.  
<http://www.i-tork.com>



# ITQ ELECTRIC QUARTER TURN ACTUATOR

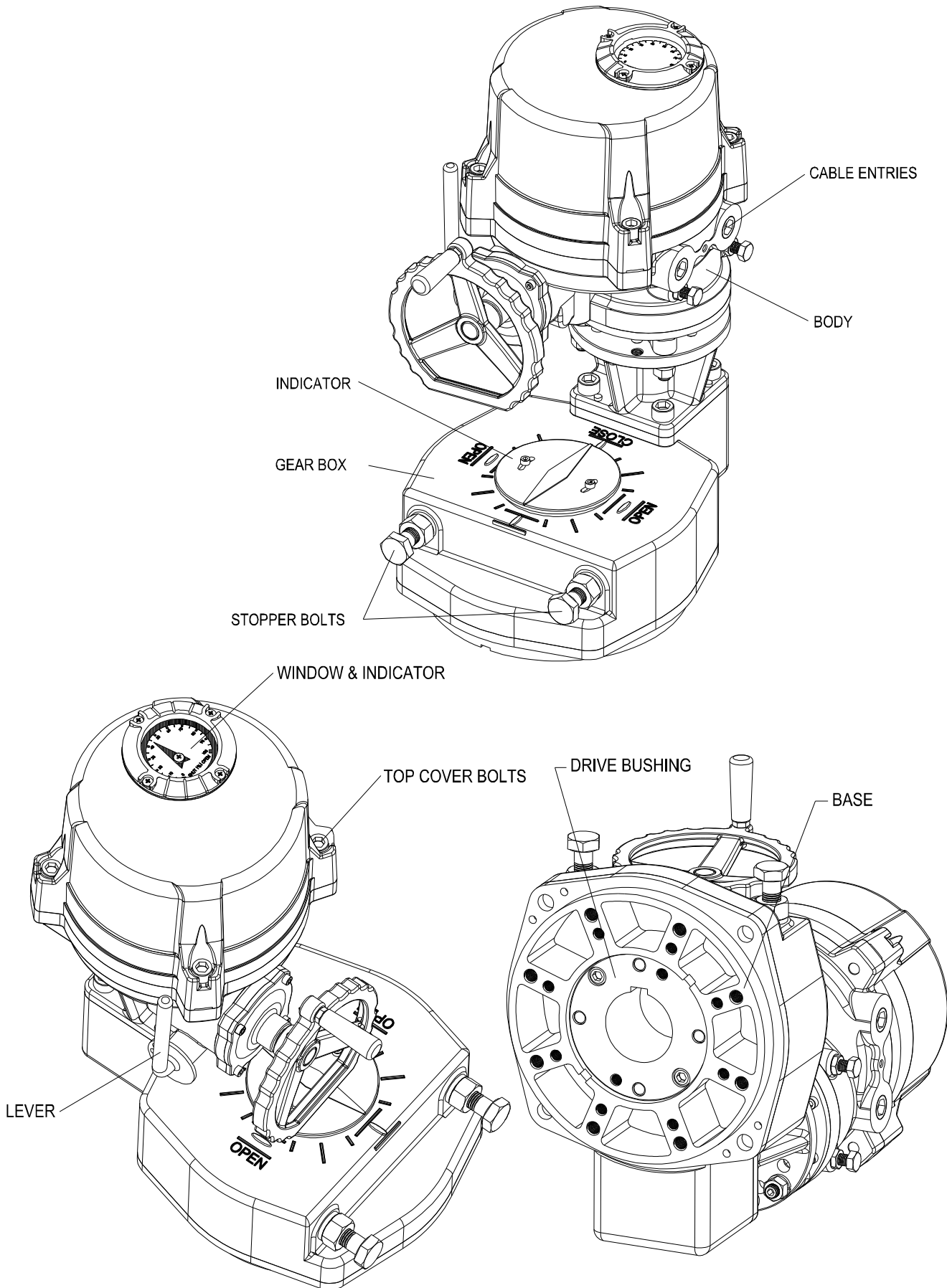

ITQ6000 ~ ITQ9000

**ITQ ELECTRIC QUARTER TURN ACTUATOR**  
**Installation and operating manual (ITQ-IMM-04-A)**

**i-tork**  
CONTROLS Ltd.  
<http://www.i-tork.com>



## 2) Internal component

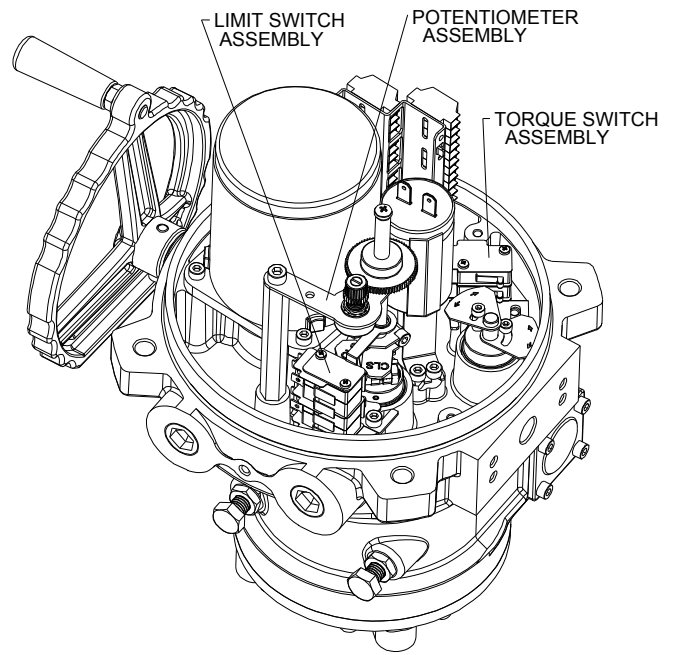
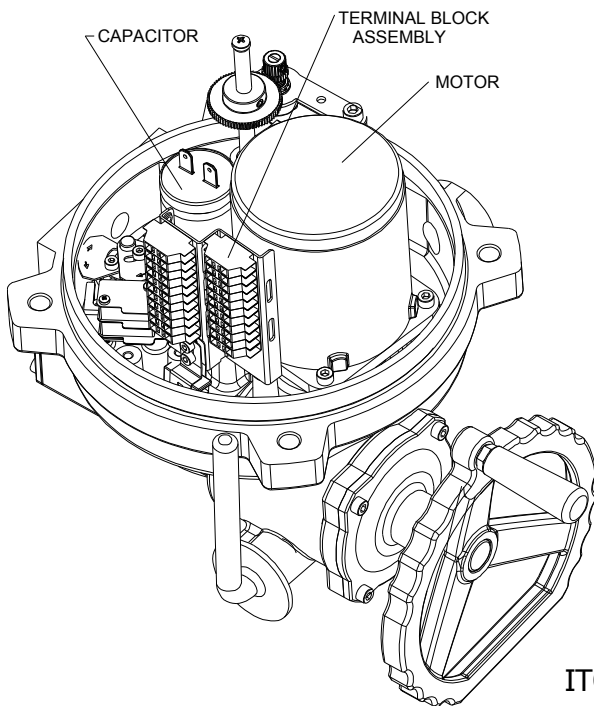

ITQ0100 ~ ITQ3000

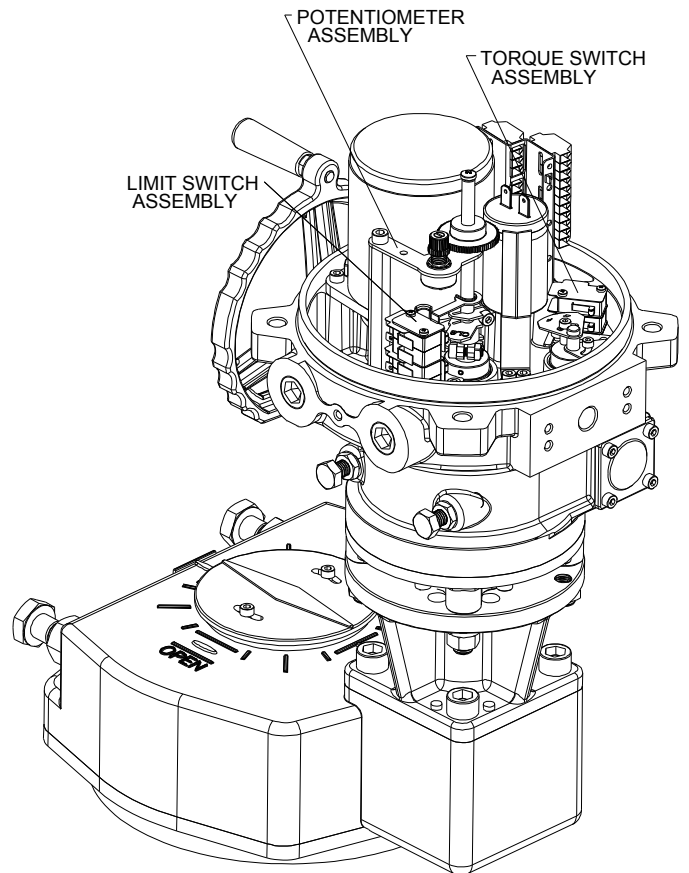
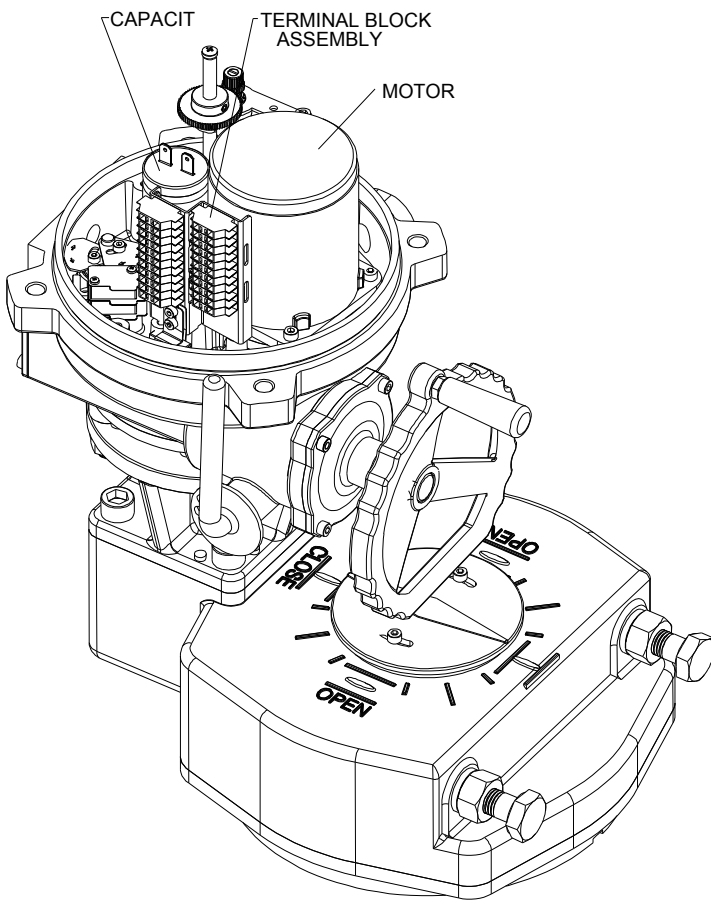

ITQ6000 ~ ITQ9000

**ITQ ELECTRIC QUARTER TURN ACTUATOR**  
Installation and operating manual (ITQ-IMM-04-A)

## 3) Specification(On-Off)

Enclosure	Weather Proof enclosure IP67, NEMA 4 AND 4X, O-RING Sealed
Main power supply	110/220V AC 1Ph, 380/440V AC 3Ph 50/60Hz, 24V DC $\pm 10\%$
Control power supply	110/220V AC 1Ph 50/60Hz, $\pm 10\%$
Duty cycle(On-Off)	S2, 20~50% Max 30Min
Duty cycle(Modulating)	S4, 30~50%, 300 ~ 1,200 starts/hour
Motor	Squirrel Caged Induction Motor
Limit switches	OPEN/CLOSE, SPDT, 250V AC 10A RATING
Torque switches	OPEN/CLOSE, SPDT, 250V AC 10A Rating(Except for ITQ0100)
Stall protection(Temp.)	Built in thermal protection, OPEN $150^{\circ}\text{C} \pm 5^{\circ}\text{C}$ /CLOSE $97^{\circ}\text{C} \pm 15^{\circ}\text{C}$
Travel angle	$90^{\circ} \pm 5^{\circ}$ ( $0^{\circ} \sim 100^{\circ}$ )
Position indicator	Plate with Indication Arrow
Manual override	Declutch-able
Self locking	Provided by double worm gears (No Brake)
Mechanical stopper	1 each for each travel end(OPEN and CLOSE), external adjustable
Heater	5W (110/220V AC) Anti-condensation
Cable entries	2- PF3/4" TAP (Option : 2-M25X1.5 for Europe, 2-NPT3/4" for America)
Lubrication	EP Type grease
Terminal block	Screw and Lever Push Type (Spring loaded)
Ambient temperature	$-20^{\circ}\text{C} \sim +70^{\circ}\text{C}$ (Except for optional electronic board)
Ambient humidity	90%RH Max, (Non-condensate)
Dielectric strength	1500V AC 1minute
Insulation resistance	500V DC 30M Ohm
Anti-vibration	X Y Z 10g, 0.2~34Hz, 30minutes
External coating	Dry powder (Polyester)

## 4) Features and structure

### (1) General :

ITQ series actuator is designed for the 90 degree turn application such as damper, ball, plug, butterfly valves and other equipment.

### (2) Wide range of torque

Min. 100Nm to Max 9000Nm.

### (3) Material

Material is hard-anodized AL alloy and external coating of epoxy powder is suitable for the severe conditions especially against corrosion. Housing is designed in accordance with the standard of ex-proof and IP67.

## (4) Sealing

Sealing provided by double O-ring system

## (5) Manual Override

Just by pulling the lever, operating mode is switched to manual. When supplying electrical power to actuator, clutch is automatically disengaged from manual and operating mode is switched to electric operation.

## (6) Gear & Self locking

2<sup>nd</sup> staged Double worm gear prevents movement caused by backward force transferred from valve provides an exact stable position of actuator and valve when electrical power is off.

High efficiency, low noise level and trouble free design are another advantage.

## (7) Manual hand-wheel

The Size of hand wheel is designed according to required torque to move the actuator, so that operator can easily move the actuator by hand.

## (8) Motor

Motor specially designed for ITQ actuator has several features such as high output power, high efficiency and thermostat installed inside of motor prevent from overheat of motor and thermal damage of motor coil.

## (9) Limit switch

Since limit switch is directly driven by the 2<sup>nd</sup> output shaft, position during operation is continuous and accurate. Setting of Cam is so easy and once cam setting is done, position is almost permanent unless operator changes setting again.

## (10) Torque switch

Torque switch driven by the 2<sup>nd</sup> output drive shaft, the position during operation is continuous and accurate. Torque spring which detects the variation of torque during operation is installed to prevent damage of valve and actuator under overload condition.

Once actuator is under overload, torque switch is tripped and actuator stops immediately.

Switches are installed for both open and close directions.

This switches set by factory can not be set again without checking with factory.

## (11) Space heater

Spacer heater is installed to prevent damage caused by condensed water inside of actuator and includes internal thermostat inside to prevent overheating.

## (12) Stopper bolt (Mechanical Travel Stops)

Stopper bolts installed for both close and open directions prevent actuator's travel over the limit during manual operation and also protect internal gearing disengagement.

## (13) Indicator

Indicator directly driven by 2<sup>nd</sup> output drive shaft

Operator perceives exact current operating situation even from a distance.

## (14) Terminal block

Spring loaded terminal strip protects vibration and provides for additional contacts.

## (15) Wiring

Basic wiring is standardized to be simply and optimal, so that variation depending on electrical specification and options can be so easy and simple.



(16) Adaption

Mounting base is designed according to ISO5211 but different dimension depending on application is also possible. Removable drive bushing provides convenient custom machining.

(17) Lubrication

Actuator is lubricated with EP type Molly Grease, no need to field lubricates.

(18) Others

ITQ guaranty high performance, high quality product throughout various and severe test and inspection.

## 5) Mounting Bases according to ISO5211 standard

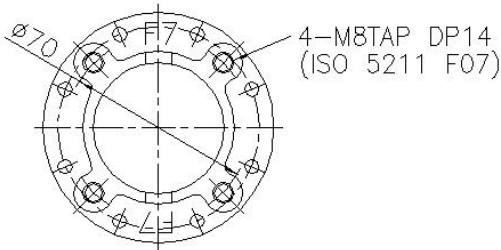

ITQ-0100

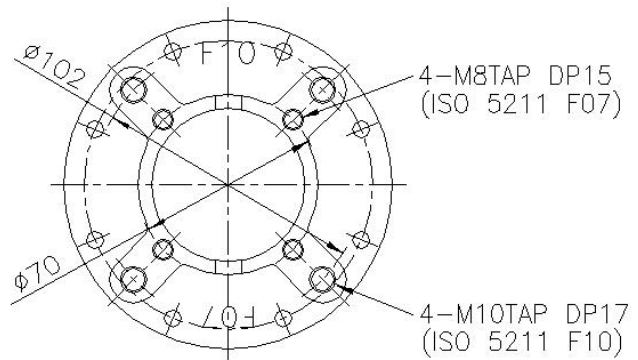

ITQ-0160, 0240

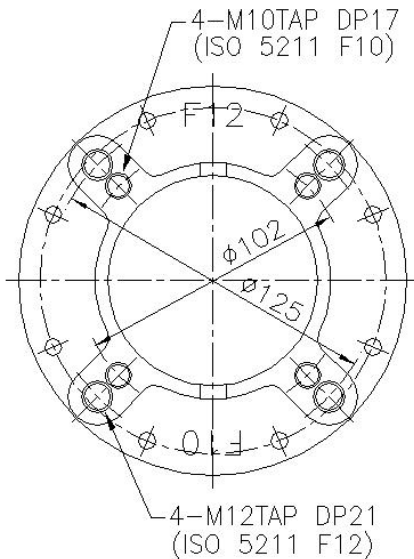

ITQ-0350, 0500

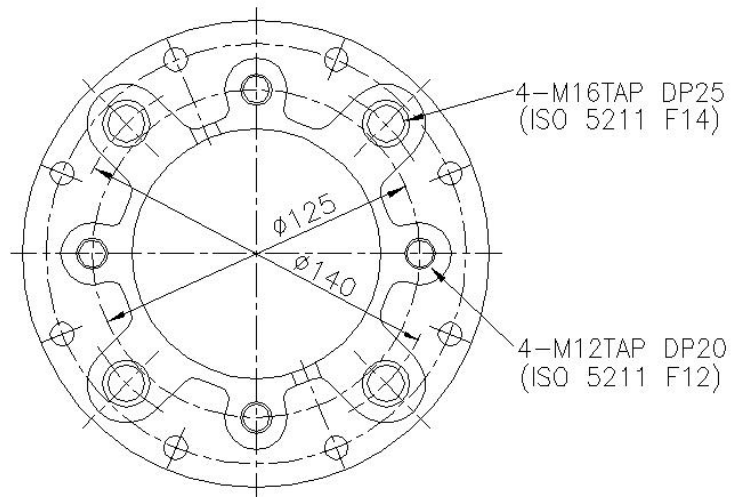

ITQ-0800, 1100

# ITQ ELECTRIC QUARTER TURN ACTUATOR

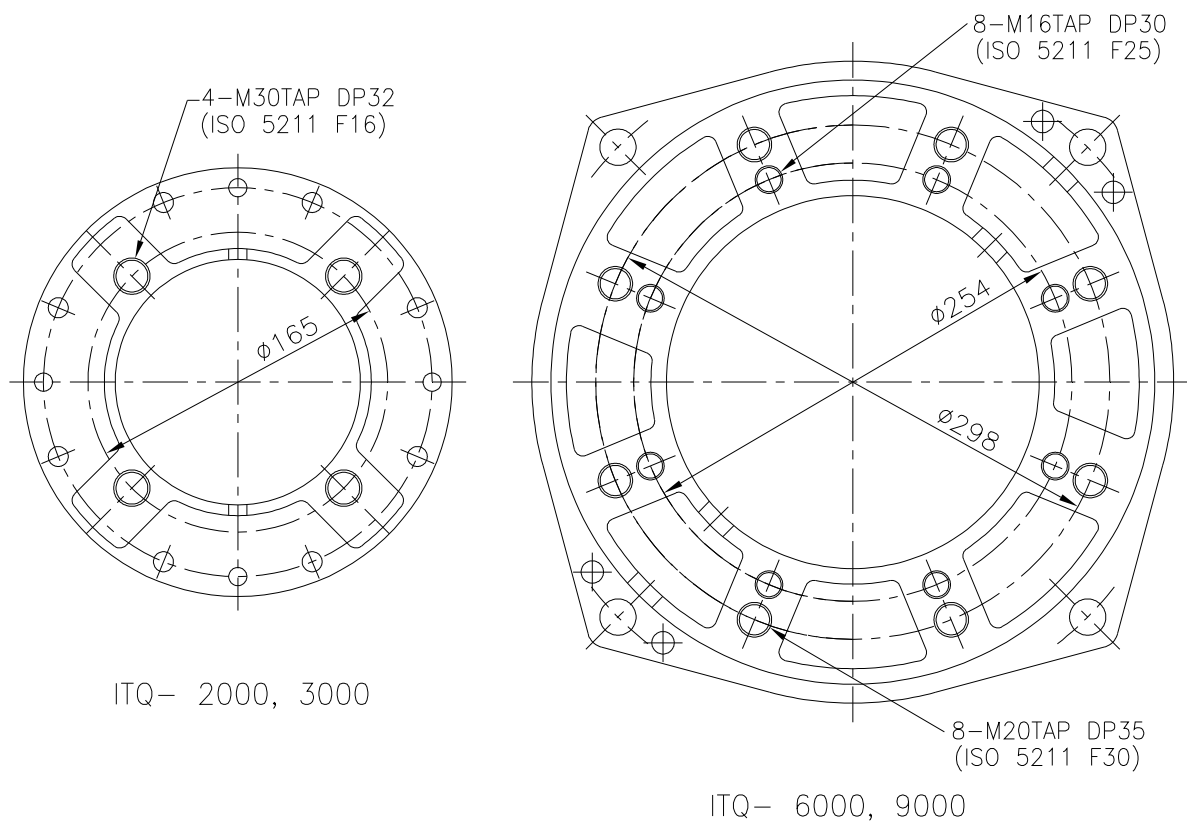

**ITQ ELECTRIC QUARTER TURN ACTUATOR**  
**Installation and operating manual (ITQ-IMM-04-A)**

**i-tork**  
CONTROLS Ltd.  
<http://www.i-tork.com>



## Removable Drive Bushings for Adaption

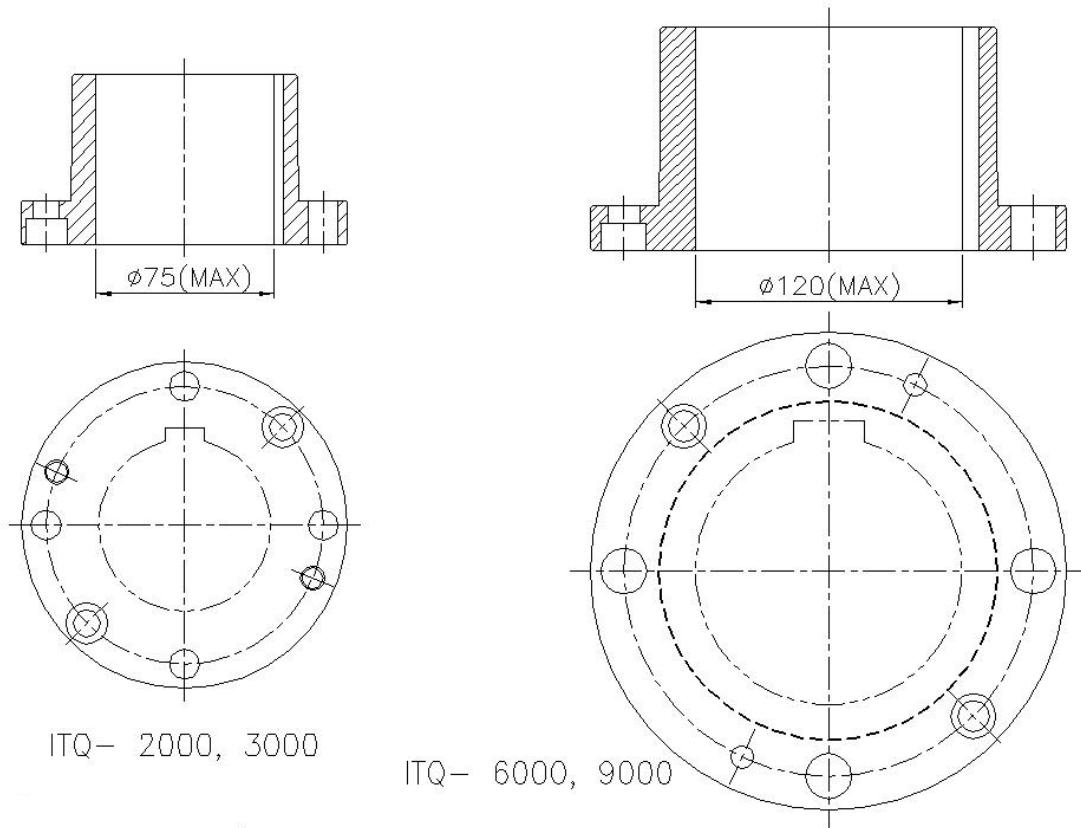
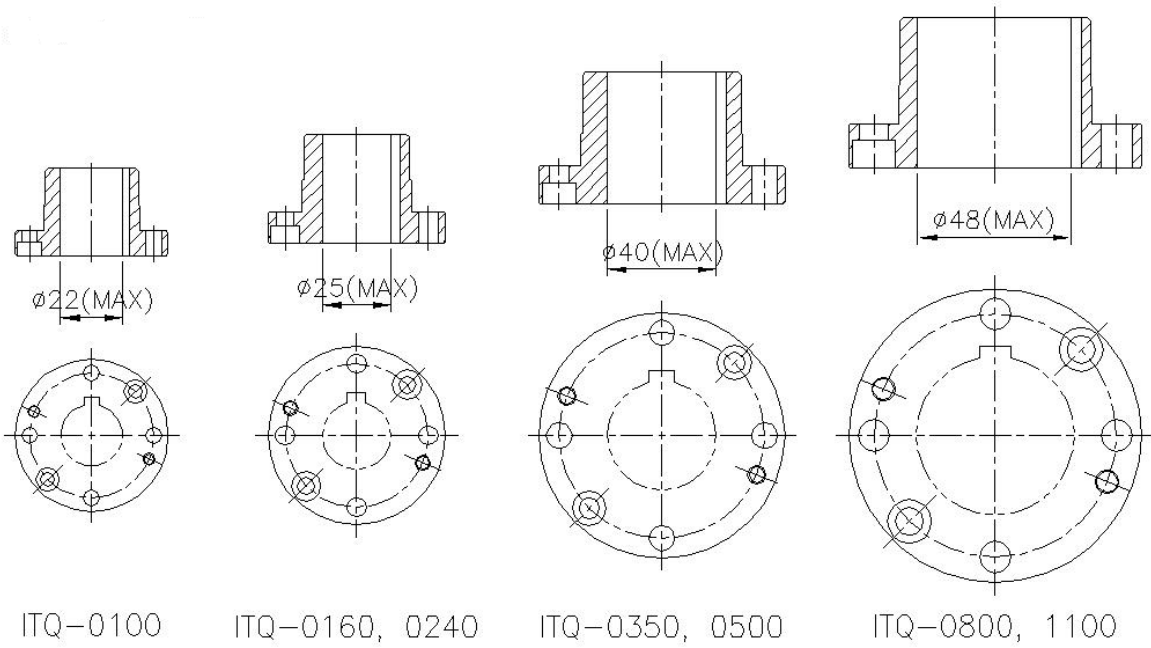

## 3. Sizing and Application

VALVE ACTUATOR	BUTTERFLY VALVE 10K (ANSI 150#)	BUTTERFLY VALVE 20K (ANSI 300#)	2-WAY BALL VALVE 10K (ANSI 150#)	2-WAY BALL VALVE 20K (ANSI 300#)	3-WAY BALL VALVE 10K (ANSI 150#)
ITQ-0100	100A(4")	80A(3")	40A	25A(1")	40A(1 1/2")
ITQ-0160	125A(5")	100A(4")	50/65A(2"/ 2 1/2")	32/40A(1 1/4"/1 1/2")	50/65A(2"/ 2 1/2")
ITQ-0240	150A(6")	125A(5")	80A(3")	50A(2")	80A(3")
ITQ-0350	200A(8")	150A(6")	100A(4")	65/80A(2 1/2"/ 3")	
ITQ-0500	250A(10")	200A(8")	150A(6")	125A(5")	125A(5")
ITQ-0800	300A(12")	250A(10")	150A(6")	125A(5")	125A(5")
ITQ-1100	350A(14")	300A(12")		150A(6")	
ITQ-2000	450A(18")	400A(16")	250A(10")	200A(8")	200A(8")
ITQ-3000	500A(20")	450A(18")	300A(12")	250A(10")	250A(10")
ITQ-6000	600/750A(24"/30")	500/600A(20"/24")	350/400A(14"/16")	300/350A(12"/14")	300A(12")
ITQ-9000	800/900A(32"/36")	700/750A(28"/30")	450/500A(18"/20")	400/450A(16"/18")	350A(14")

Note :1. The above table just shows as a reference and no guaranty!

2. Sizing should be done after careful reviewing valve factory, temperature, characteristics of fluid and etc.
3. Review the application under the special conditions such as high and low temperature, seawater, severe corrosion, high vibration, please consult with our technical dept before selecting actuator.
4. Decision by user ignoring our recommendation voids all factory warranties.

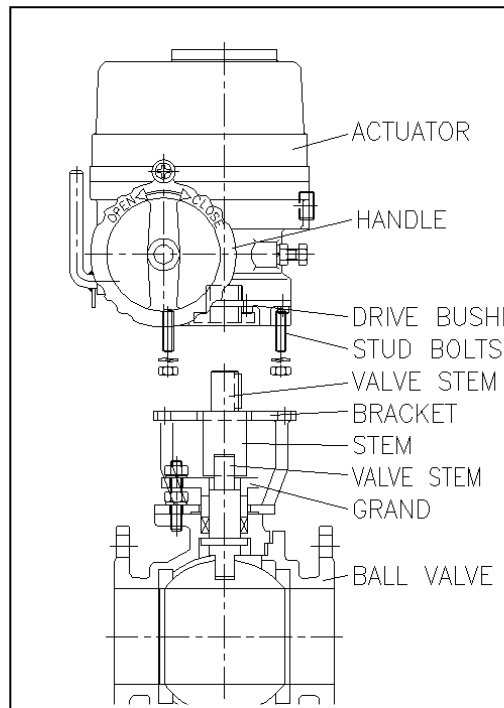
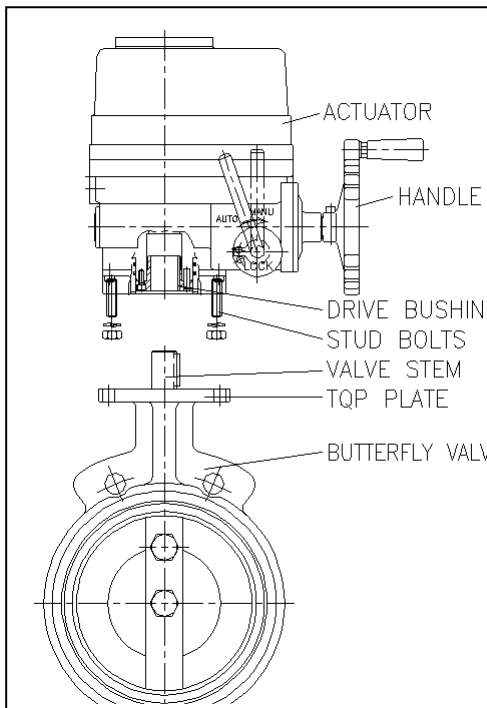

## 4. Setting

### 1) Manual Operation

- ① Pull the lever toward hand-wheel until lever moves perpendicular to pipeline.
- ② If lever does not move, try again while turning hand-wheel slowly.
- ③ There is a casting mark to indicate rotating direction on hand-wheel
- ④ Clockwise is the close direction and counter clockwise is the open direction.
- ⑤ There is no need to position the lever back to the original position for electrical operation.
- ⑥ Once electrical power is on, the lever will automatically return its original position by internal clutch mechanism.

### 2) Limit Switch Setting

- ① Pull the lever for manual operation and turn hand-wheel to move actuator full close(Or open) position
- ② Loosen the bolts tightening cam by L-wrench, and turn CLS (Or OLS) cam to CW (or to CCW), so that cam may hit the lever of close (Or open) limit switch.
- ③ Then tighten the bolt by L-wrench

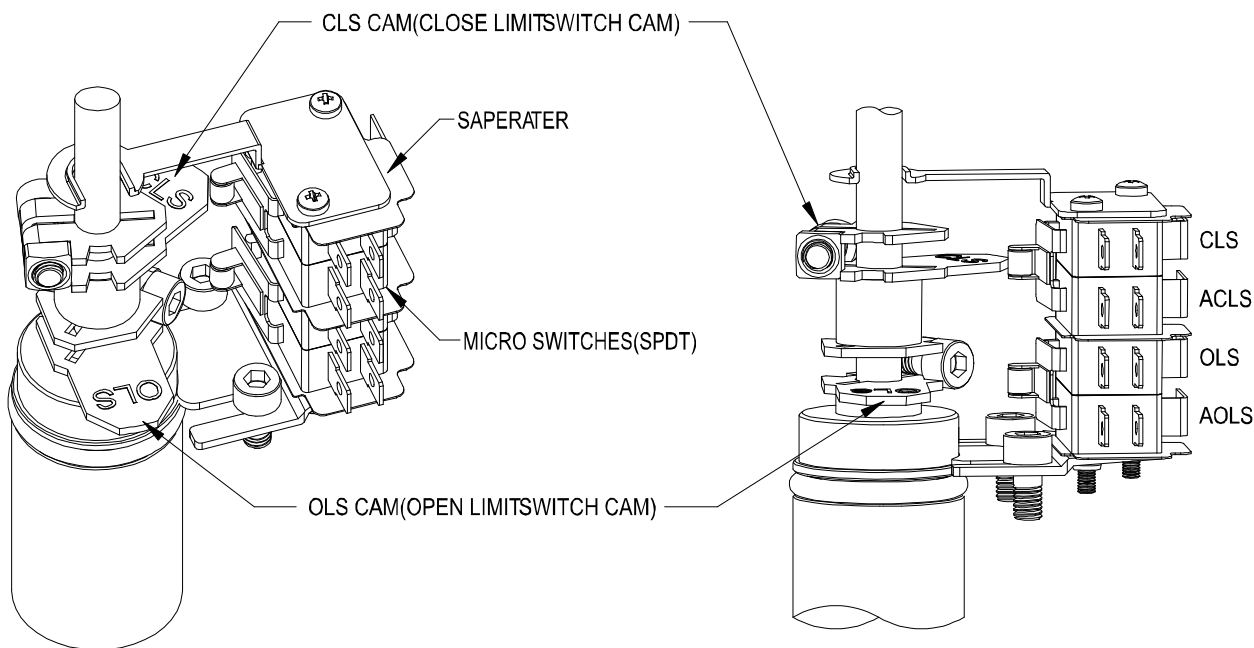

### 3) Torque Switches

Torque Switches are set by factory before delivery and therefore no need to set the switches again, to check function:

- ① Push the lever of close switches by screw driver until it sounds "click" sound is heard, actuator should stop immediately. If it stops, switch is functional.
- ② Check open switches as per just above.
- ③ There is no guaranty in performance if settings are changes.
- ④ Before changing setting, please consult with factory.

## 4) Stopper Bolt (Travel Stop) Setting

- ① Before manual operation, loosen both nuts and turn stopper bolt outward by 3 ~ 4 threads.
- ② Move actuator manually to full close position.  
Once cam hit the lever of limit switch to trip, stop manual operation.
- ③ Then turn close stopper bolt inward until it stops (End of stopper bolt contacts the 2<sup>nd</sup> worm gear).
- ④ Turn close stopper bolt out by 2 threads and tighten the nut.
- ⑤ Repeat same above for open stopper bolt setting.

## 5) Indicator Setting

- ① Move actuator full close position and turn indicator by hand until orientation of indicator is aligned to the figure of window.
- ② Tighten the bolt (Be careful not to be injured by the cutting edge of indicator and leakage of electricity when power is on).
- ③ Figure of Window and indicator according to AWWA standard.

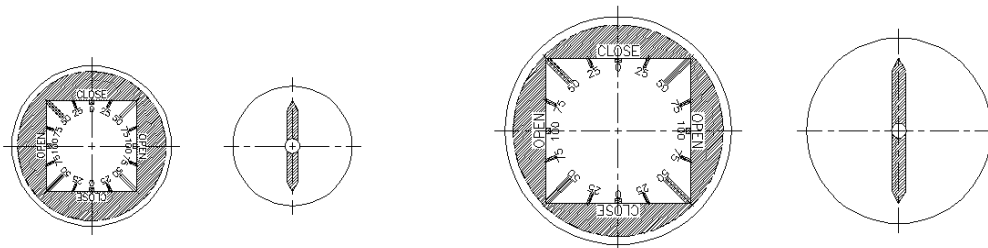

ITQ0100

ITQ0160~ITQ3000

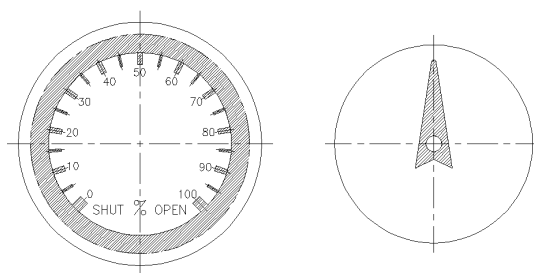

ITQ6000~ITQ9000

## 5. Recommendation for installation of actuator in the pipeline

### 1) Location of actuator on the pipeline

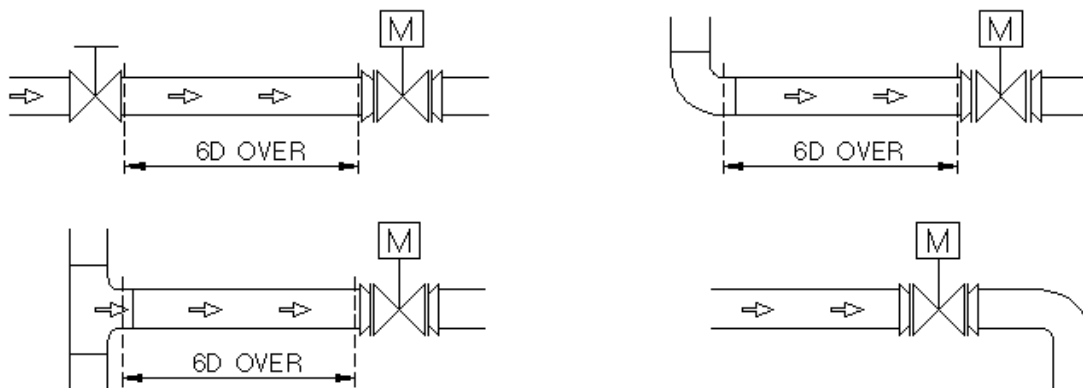
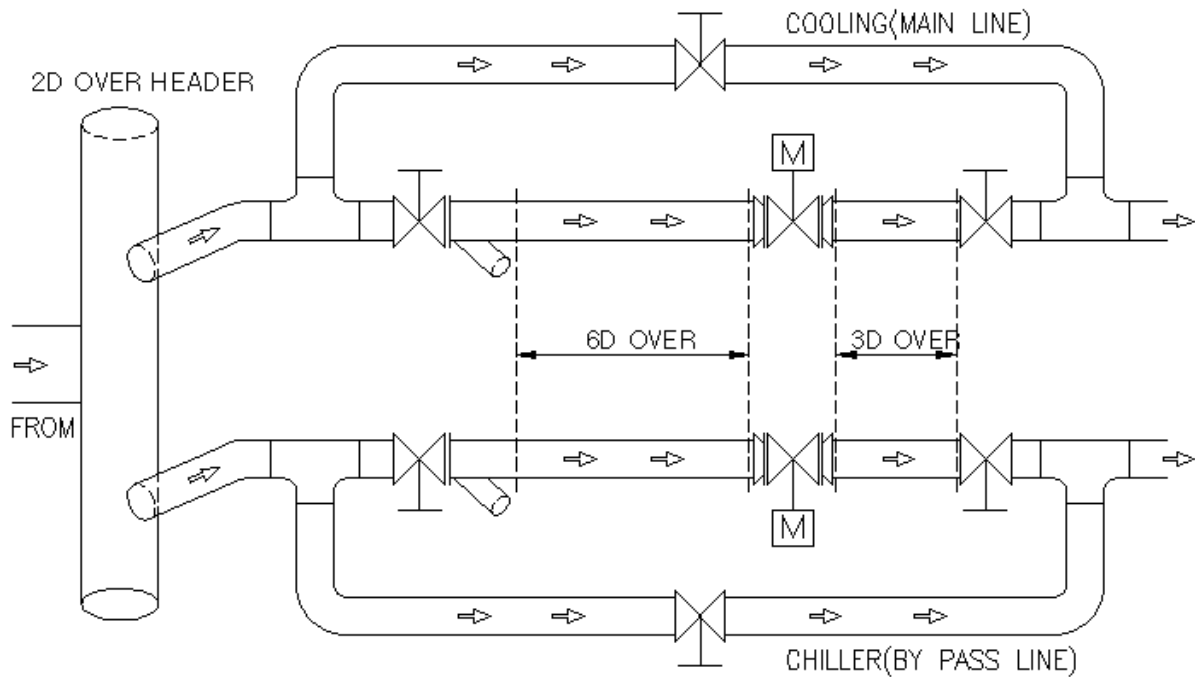

### 2) Orientation of installation of actuator

- ① It is recommended to install actuator in the position where cable entry is bottom orientated for watertight function and hand-wheel faces front for easy manual operation.
- ② Reserve the space for maintenance.

## 6. Electrical wiring

### 1) Before wiring

- ① Cable entries are machined with PF3/4" (NPT3/4", M20X1.5) tap and sealed by Plug before delivery.
- ② Please retain any unused plugs for both cable entries.
- ③ Please make sure to seal the entries by using rubber or metallic packing after wiring, so that water may not enter the actuator.
- ④ On ex-proof models, please make sure to use the certified connection component which is at least same grade with actuator.
- ⑤ The certified connection component is not our scope of supply, but if user don't use suitable component, factory won't guaranty the performance of ex-proof actuator.

### 2) Electrical wiring

- ① Check if electrical specifications like as power, wiring, etc are correct.
- ② A wiring diagram is supplied with actuator.
- ③ Wiring should be done as per the given wiring diagram, such as power, control power, internal wiring and ground.
- ④ Make sure to supply electric power to heater for keeping inside of actuator clean and dry.
- ⑤ Make sure to check wiring to the terminal is secure.
- ⑥ **Make sure that one relay operates one actuator only(Can not operate two or more actuators simultaneously)**
- ⑦ Make sure to clean inside of actuator and no foreign material inside.

### 3) Check rotating direction

- ① In 3 phase actuator, operator should check the rotating direction of actuator before electrical operation.
- ② If operating direction is wrong, limit switches don't function and will result in damage from jamming or motor overheating.
- ③ Set the actuator at 50% open (or Close) position by manual operation and supply power to the actuator and check it's rotating direction.
- ④ If actuator moves open as per open signal, the direction it is O.K, but reverse, change the wiring.
- ⑤ Among 3 of power wires, change 2 wires each other.
- ⑥ Then check the rotating direction again in order to confirm.

### 4) Commissioning

- ① Make sure to check the rotating direction of actuator first before operation.
- ② Check the function of limit and torque switches, direction of indicator and space heater.
- ③ Check lever movement (Manual override)
- ④ Check the lamps in the control panel.
- ⑤ After commission, please make sure to tighten the 4 bolts of the top cover and to do proper sealing.



## 7. Others

### 1) Jamming

- ① In case that actuator moves wrong direction and moves further beyond the travel limit, internal worm gear contacts the stopper bolt and engaged each other. This is so call jamming and won't move at all.
- ② How to solve
  - Turn off power
  - If jamming happens during close rotation, loosen stopper bolts take close by about 2 ~3 threads
  - Pull the lever and put it manual position.
  - Turn hand-wheel to counterclockwise until 50% open position.
  - Check rotating direction again.
  - If everything is O.K, put stopper bolt in original position.
  - When jamming happens during open rotation, procedure is same as close, but turn hand-wheel to clockwise by manual.

### 2) Special tools for setting

- ② L-Wrench 1 set(Metric)
- ③ Screw drivers (--, +)
- ④ Spanner set (Metric), Monkey spanner 200mm, 300mm 1 each,
- ⑤ Wire stripper, Long nose, Light
- ⑥ Multi Meter (AC, DC Volt, Resistance)
- ⑦ DC signal generator (0~4mA DC) : RPC option
- ⑧ mA DC Meter (0~25mA DC) : RPC and CT

## 8. Caution

- ① Selection of valve and actuator: Review all specification of valve and actuator carefully before making selection and reserve about 30% torque of actuator for safety purpose. If required torque is 90Kg-m, recommended actuator torque is about 117Kg-m.
- ② Option: Please consult with factory before making selection, if possible.
- ③ Before setting limit switch, please don't operate actuator full open or full close.
- ④ After electrical wiring, make sure to secure the sealing of cable entries.
- ⑤ Before operating actuator, please review this manual carefully and follow the instruction without fail. Please be careful at temperature, humidity, vibration, voltage drop.
- ⑥ Storage: Keep actuator dry, clean and cool.
- ⑦ Trouble shooting: Please refer to following trouble shooting but please don't dismantle the actuator without consulting with factory.
- ⑧ If repair or maintenance is required, please check the model, electrical condition, serial Number and current situation to inform factory

## 9. Trouble Shooting

110/220 V AC 1Ph, 380~440 V AC 3Ph, 24 V DC

Trouble	Cause	Counter plan
Actuator doesn't work at all	Check if power is on	Power on
	Check if voltage is too low	Check power
	Motor and supplied power is different	Check motor power and supplied power
	Wiring is not correct and tight or loosen	Do wiring again tightly
	Coil of motor is damaged	Replace the motor
	Thermostat of motor trips	Replace thermostat
	Capacitor is damaged	Replace the capacitor
	Setting of limit and torque switch is not correct	Do setting switches again
	Jamming happens	Check rotating direction per instruction
Torque switch open	Actuator is undersized	Select again as per real require
	Foreign material between valve seat and disc	Remove foreign material
	Stopper bolt is set prior to limit switch	Reset the stopper bolt
Switching to manual is not possible	Lever is not fully pulled over	Fully pull over the lever
	Lever is not pulled over because of jamming	Disengage the jamming
	Clutch of lever and handle is engaged each other	Turning handle slowly, pull over lever
Abnormal signal indicator	Damage of signal LED	Replace the signal LED
	Damage of micro switches	Replace the micro switches
	Limit Switch Setting is wrong	Reset switch
	Stopper bolt is set prior to limit switch	Reset stopper bolt

## 10. Maintenance

### 1) Lubrication

Lubrication is already done by factory and generally no need field lubricate.

In places such as very dry condition below R.H 15% or high temperature higher than 30°C, it is required to lubricate every two years.

### 2) Regular operation

Electrical power always should be supplied to actuator and it is recommended to operate actuator once a week.

### 3) Maintenance

Please check operating condition, corrosion, painting, etc at regular intervals.

### 4) Others

Should you have any further queries, please contact us through Phone, fax and E-mail without hesitation.